

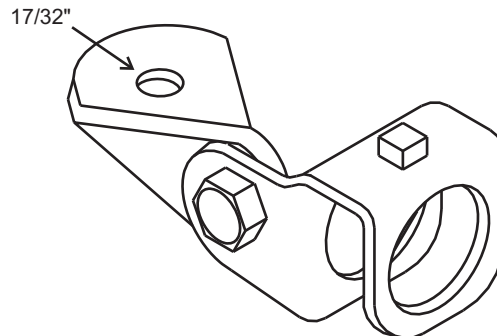

P.O. Box 3365 South El Monte, CA 91733 626.444.0541 Fax 626.444.3887 www.Afcon.org

077

ATTACHMENT FITTING LOCKING



077S STEEL BASE PLATE

SIZE - BRACE PIPE: 1" and 1 1/4" Sch. 40

MATERIAL - Carbon Steel or S.S. (Type 304).

FINISH - Plain or E.G.

LISTING/APPROVAL -

 203A-EX2625
  FM Approved - 1950
 OSHPD See Website.

FUNCTION - Structure attachment fitting of an *AFCON* sway brace assembly.

INSTALLATION - Per these instructions

including NFPA 13 or FM 2-8.

Load rating - see chart.

ASSEMBLY

Combine with proper *AFCON* components- see disclaimer below.

Insert brace pipe thru fitting near pivot bolt.

Tighten set bolt until head contacts bracket.

FEATURES

- * Swivel allows attachment at any angle.
- * Visual inspection, verifies proper installation.
- * Larger fastener hole available.- Consult factory.

ORDERING - Part #, size - brace pipe and finish.

	Max. Horizontal Load	
	30° thru 90°	2015

	Max. ASD Horizontal Load			
	30°-44°	45°-59°	60°-74°	75°-90°
	630	870	1620	1810

FASTENERS

Specific *AFCON* products are exclusively designed to be compatible **ONLY** with other *AFCON* products including parts and fasteners, resulting in a listed sway brace, restrainer or hanger assembly. **Be advised** the following warranty restriction will apply. **DISCLAIMER -** *AFCON* will **NOT** warrant against the failure of its products when used in combination with other products, parts or systems not manufactured or sold by *AFCON*. *AFCON* shall **NOT** be liable under any circumstances whatsoever for any direct or indirect, incidental or consequential damages of any kind, including but not limited to loss of business or profit, when non-*AFCON* products have been, or are used.