

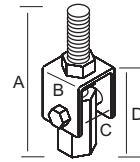

P.O. Box 3365 South El Monte, CA 91733 626.444.0541 Fax 626.444.3887 www.Afcon.org

615

SWIVEL

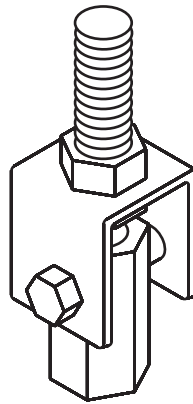
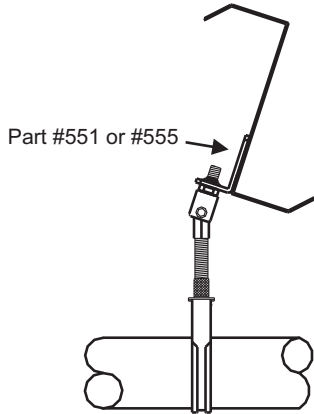

Dimensions					
Size	A	B	C	D	Rod Make-up
3/8"	2.96	0.75	1.19	1.54	0.78
1/2"	3.62	0.76	0.97	1.75	0.72

SIZE - ROD: 3/8" **SIZE - SYSTEM PIPE:** 4" max.
SIZE - ROD: 1/2" **SIZE - SYSTEM PIPE:** 8" max.

MATERIAL - Carbon Steel or S.S. (Type 304).

FINISH - Mil. Galvanized and E.G.

LISTING/APPROVAL -



FUNCTION - Pivot component of an *AFCON* hanger.

Used to provide angularity of the hanger assembly.

To support horizontal piping.

INSTALLATION - Per NFPA 13 and these instructions.

FEATURES

- * Deep tapped rod bore.
- * Improved hanger adjustment.
- * More pivot clearance at T.B.C. - See detail A.

ORDERING - Part #.

